

EXTERNAL TURNING TOOLS

外圆车刀系列

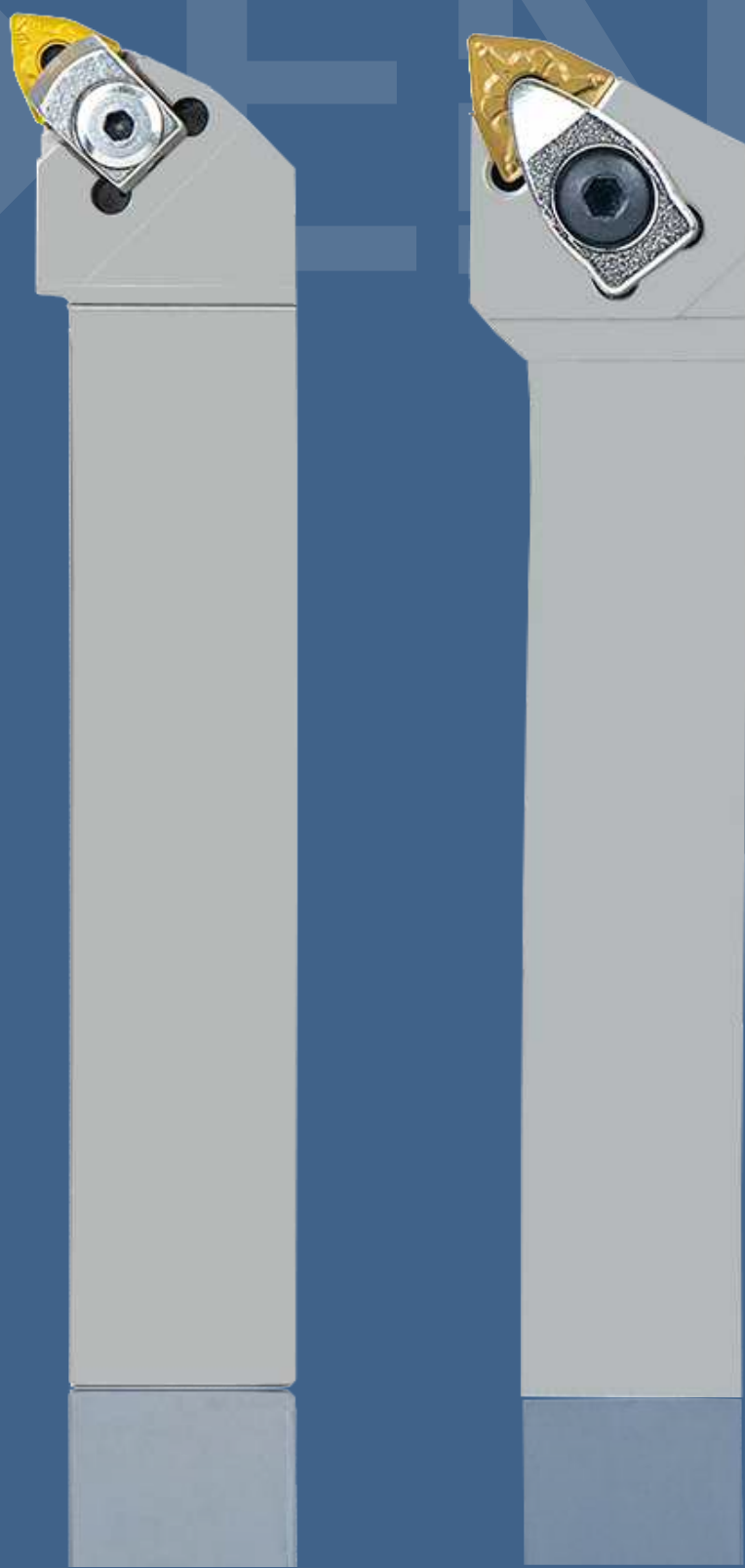

Toolholder Clamping System 刀杆压紧系统

D-Clamp Type
D型压紧方式

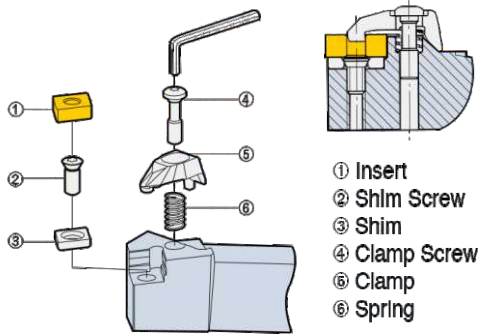

M-Multi Lock Type
M型压紧方式

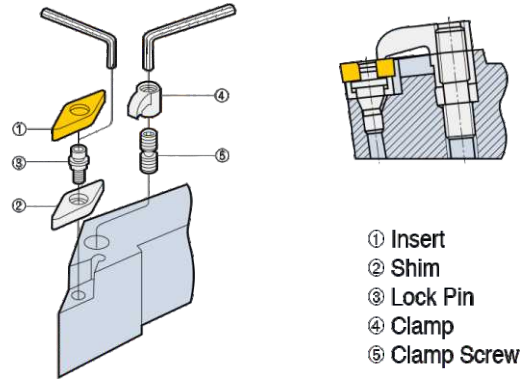

S-Screw Clamp Type
S型压紧方式

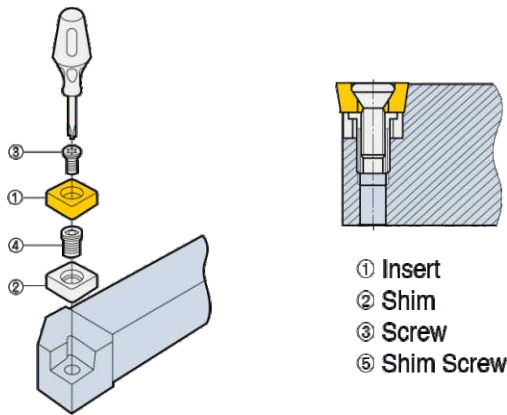

W-Wedge Clamp Type
W型压紧方式

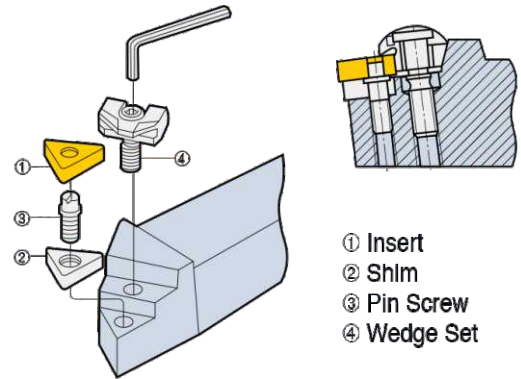

B-Clamp Holder
B型压紧方式

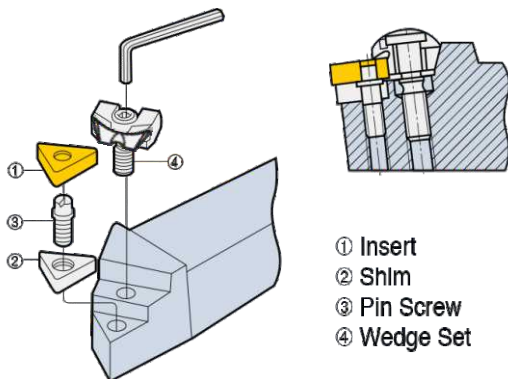

P-Lever Type
P杠杆型压紧方式

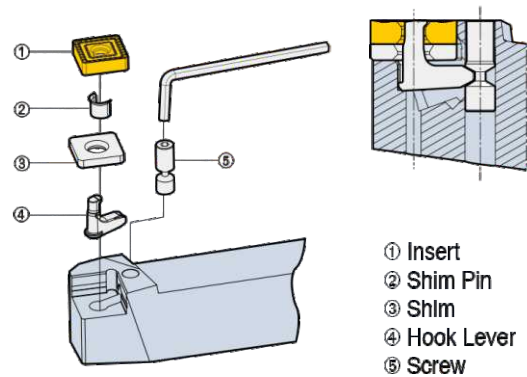

External Turning Toolholders Identification System 外圆车刀识别系统

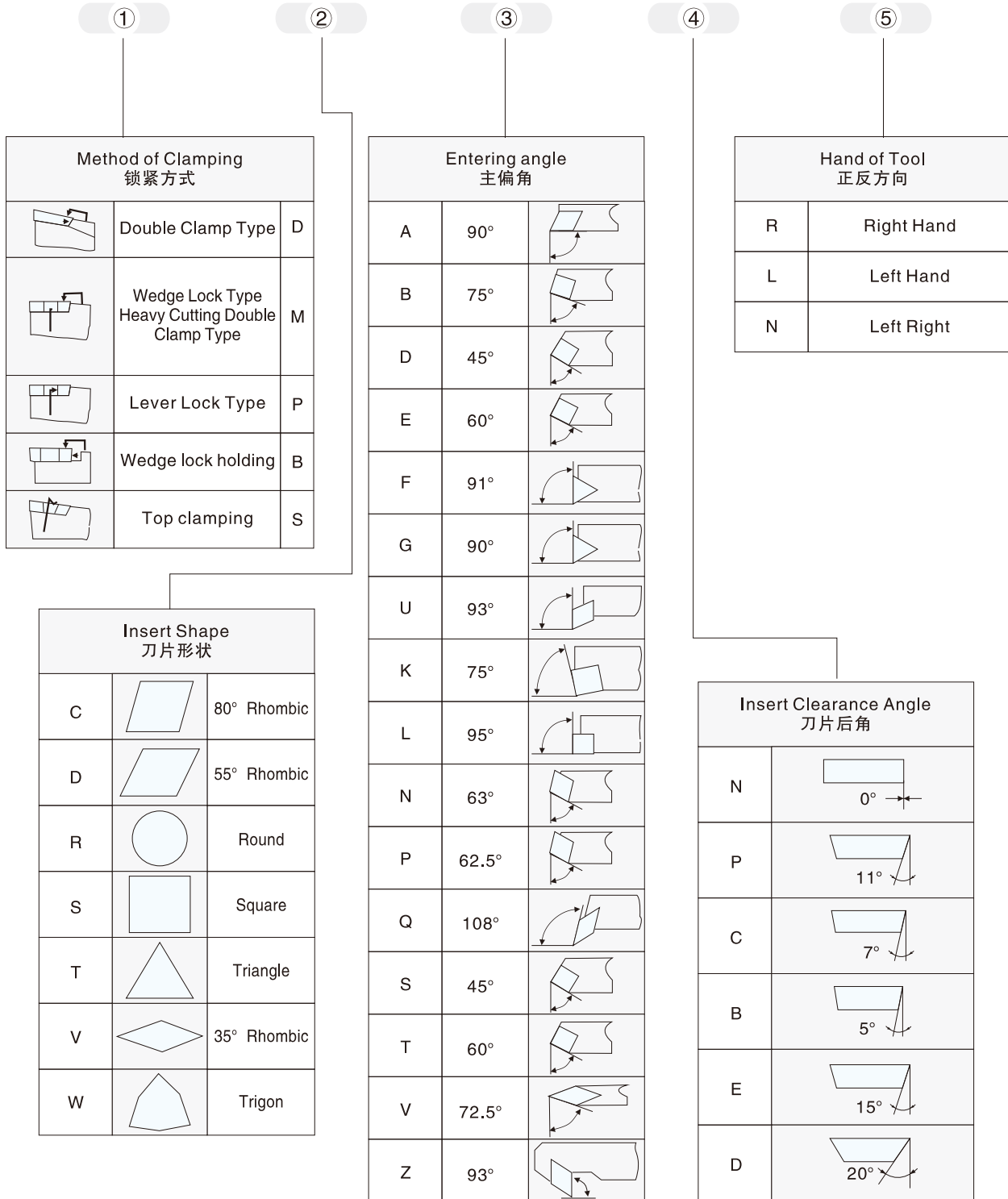

External Turning Toolholders Identification System 外圆车刀识别系统

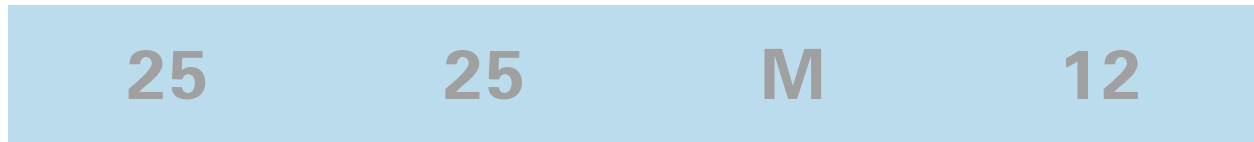

⑥

Shank Size(mm) 柄径(mm)	
8	8
10	10
12	12
16	16
20	20
25	25
32	32

⑥

Tool Length(mm) 总长(mm)	
D	60
E	70
F	80
H	100
K	125
M	150
P	170
Q	180
R	200

⑦

Cutting Edge Length(mm) 切削刃长度(mm)						
Insert IC(mm)	Insert Shape					
	Square	Triangle	Round	80° Rhombic	55° Rhombic	35° Rhombic
6	-	-	06	-	-	-
6.35		11		06	07	11
7.94	-	13	-	-	-	-
8			08			
9.525	09	16	-	09	11	16
10	-	-	10	-	-	-
12	-	-	12	-	-	-
12.7	-	22	-	12	15	-
15.875	15	27	-	16	-	-
16	-	-	16	-	-	-
19.05	19	-	19	-	-	-
20	-	-	20	-	-	-
25	-	-	25	-	-	-
25.4	25	-	-	-	-	-
32	-	-	32	-	-	-

⑧

MCLNR/L

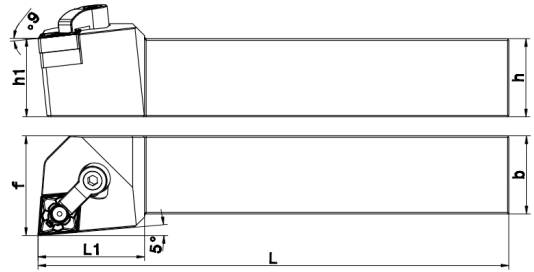
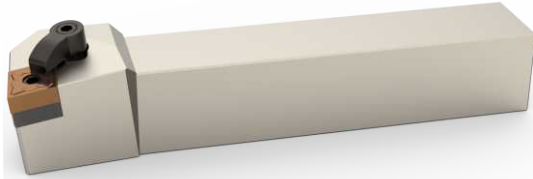

Ordering Code (规格型号)	Stock (库存)		Dimensions/mm (尺寸/mm)						刀片 Insert	刀垫 Pad	销钉 Pin	压板 Pressing plate	双头螺钉 Screw	扳手 Wrench
	R	L	h	b	L	L1	h1	f						
MCLNR/L1616H12	●	●	16	16	100	34	16	20						
MCLNR/L2020K12	●	●	20	20	125	34	20	25	CN**1204	CN-1204	MXD0617	MYB1814	ST0625	L3.0
MCLNR/L2525M12	●	●	25	25	150	34	25	32						

PCLNR/L

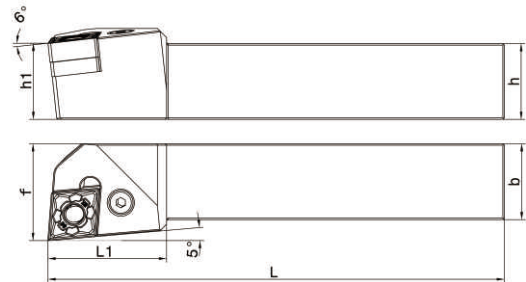
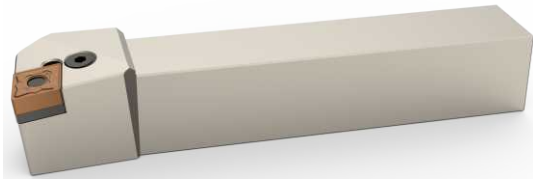

Ordering Code (规格型号)	Stock (库存)		Dimensions/mm (尺寸/mm)						刀片 Insert	刀垫 Pad	杠杆 Level	垫销 Shim	螺钉 Screw	扳手 Wrench
	R	L	h	b	L	L1	h1	f						
PCLNR/L2020K12	●	●	20	20	125	28	20	25						
PCLNR/L2525M12	●	●	25	25	150	28	25	32	CN**1204	CN-P1203	GGX0514	DX0606	NLJ0820-P	L3.0
PCLNR/L3232P12	●	●	32	32	170	30	32	40						
PCLNR/L2525M16	●	●	25	25	150	33	25	32	CN**1606	CN-P1604	GGX0617	DX0808	NLJ0821-P	
PCLNR/L3232P16	●	●	32	32	170	33	32	40						L5.0
PCLNR/L3232P19	●	●	32	32	170	40	32	40	CN**1906	CN-P1904	GGX0820	DX0909	NLJ1027-P	
PCLNR/L4040S19	●	●	40	40	170	40	40	50						

DCLNR/L

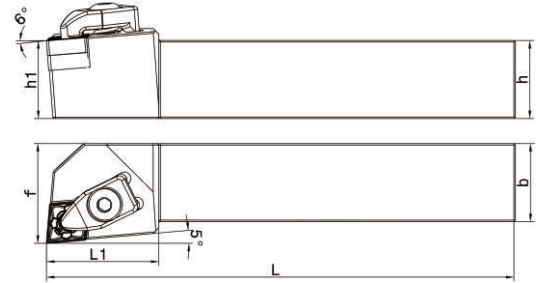
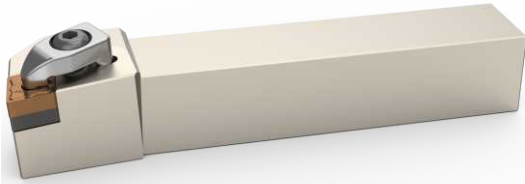

Ordering Code (规格型号)	Stock (库存)		Dimensions/mm (尺寸/mm)						刀片 Insert	刀垫 Pad	销钉 Pin	压板 Pressing plate	固定螺钉 Screw	弹簧 Screw	扳手 Wrench
	R	L	h	b	L	L1	h1	f							
DCLNR/L1616H12	●	●	16	16	100	35	16	20	CN**1204	CN-1204	DXD0614	DYB2413A	ZZM0616	TH0810	L3.0 L4.0
DCLNR/L2020K12	●	●	20	20	125	35	20	25							
DCLNR/L2525M12	●	●	25	25	150	38	25	32							
DCLNR/L3232P12	●	●	32	32	170	38	32	40							

BCLNR/L

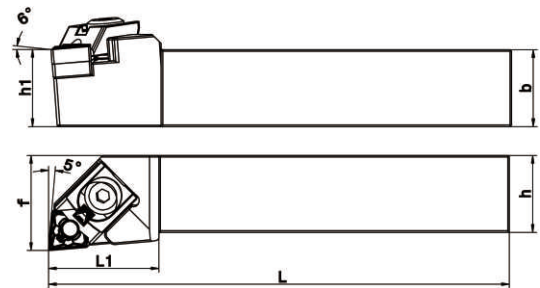
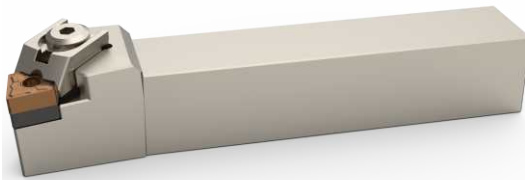

Ordering Code (规格型号)	Stock (库存)		Dimensions/mm (尺寸/mm)						刀片 Insert	刀垫 Pad	销钉 Pin	压板 Pressing plate	固定螺钉 Screw	弹簧 Screw	扳手 Wrench
	R	L	h	b	L	L1	h1	f							
BCLNR/L2020K12	●	●	20	20	125	32	20	25	CN**1204	CN-1204	CTM6-S	BC12	BCS08	CR07	L3.0 L4.0
BCLNR/L2525M12	●	●	25	25	150	35	25	32							

DCBNR/L

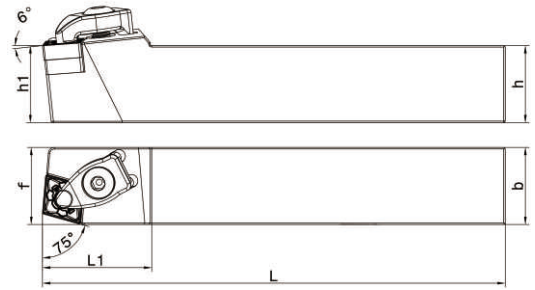

Ordering Code (规格型号)	Stock (库存)		Dimensions/mm (尺寸/mm)						刀片 Insert	刀垫 Pad	销钉 Pin	压板 Pressing plate	固定螺钉 Screw	弹簧 Screw	扳手 Wrench
	R	L	h	b	L	L1	h1	f							
DCBNR/L1616H12	●	●	16	16	100	32	16	20	CN**1204						
DCBNR/L2020K12	●	●	20	20	125	34	20	20							
DCBNR/L2525M12	●	●	25	25	150	34	25	25							
DCBNR/L3232P12	●	●	32	32	170	34	32	32							

DCMNN

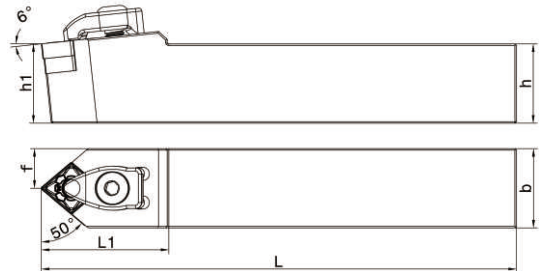

Ordering Code (规格型号)	Stock (库存)		Dimensions/mm (尺寸/mm)						刀片 Insert	刀垫 Pad	销钉 Pin	压板 Pressing plate	固定螺钉 Screw	扳手 Wrench
	R	L	h	b	L	L1	h1	f						
DCMNN2020K12	●	●	20	20	125	35	20	10	CN**1204					
DCMNN2525M12	●	●	25	25	150	35	25	12.5						
DCMNN2020K12-100	●	●	20	20	125	35	20	10						
DCMNN2525M12-100	●	●	25	25	150	35	25	12.5						

DDJNR/L

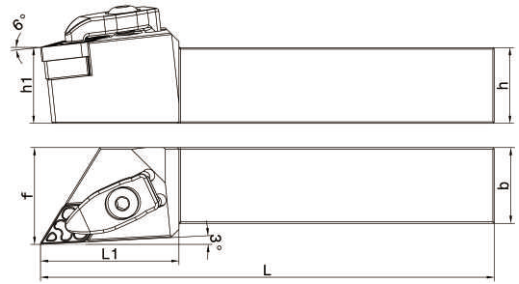

Ordering Code (规格型号)	Stock (库存)		Dimensions/mm (尺寸/mm)						刀片 Insert	刀垫 Pad	销钉 Pin	压板 Pressing plate	固定螺钉 Screw	弹簧 Screw	扳手 Wrench	
	R	L	h	b	L	L1	h1	f								
DDJNR/L1616H11	●	●	16	16	100	32	16	20								
DDJNR/L2020K11	●	●	20	20	125	32	20	25	DN**1104	DN-1103	DXD0512	DYB2413B	ZZM0616	TH0810	L4.0 L2.5	
DDJNR/L2525M11	●	●	25	25	150	32	25	32								
DDJNR/L2020K1504	●	●	20	20	125	41	20	25								
DDJNR/L2525M1504	●	●	25	25	150	41	25	32	DN**1504	DN-1506	DXD0614	DYB3113	ZZM0616	TH0810	L4.0 L3.0	
DDJNR/L3232P1504	●	●	32	32	170	41	32	40								
DDJNR/L2020K1506	●	●	20	20	125	41	20	25								
DDJNR/L2525M1506	●	●	25	25	150	41	25	32	DN**1506	DN-1504	DXD0614	DYB3113	ZZM0616	TH0810	L4.0 L3.0	
DDJNR/L3232P1506	●	●	32	32	170	41	32	40								

PDJNR/L

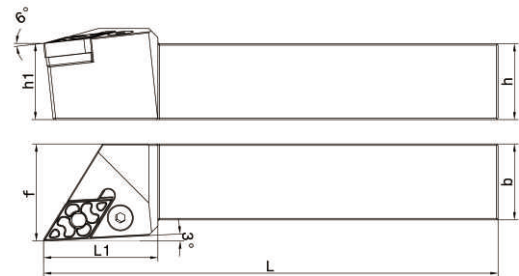
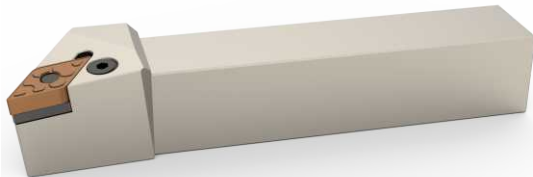

Ordering Code (规格型号)	Stock (库存)		Dimensions/mm (尺寸/mm)						刀片 Insert	刀垫 Pad	杠杆 Level	垫销 Shim	螺钉 Screw	扳手 Wrench	
	R	L	h	b	L	L1	h1	f							
PDJNR/L2020K11	●	●	20	20	125	32	20	25							
PDJNR/L2525M11	●	●	25	25	150	32	25	32	DN**1104	DN-P1103	GGX0312	DX0505	NLJ0618-P		
PDJNR/L2020K1504	●	●	20	20	125	41	20	25							
PDJNR/L2525M1504	●	●	25	25	150	41	25	32	DN**1504	DN-P1503	GGX0514	DX0606	NLJ0820-P	L3.0	
PDJNR/L2020K1506	●	●	20	20	125	41	20	25							
PDJNR/L2525M1506	●	●	25	25	150	41	25	32	DN**1506	DN-P1503	GGX0514D	DX0606	NLJ0821-P		

DDQNR/L

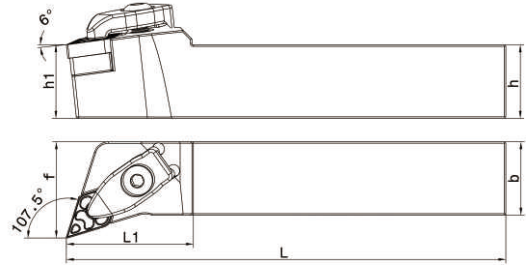
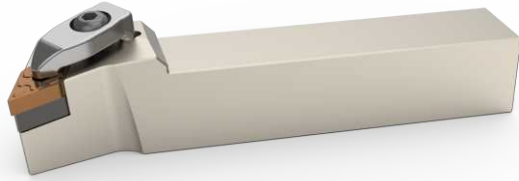

Ordering Code (规格型号)	Stock (库存)		Dimensions/mm (尺寸/mm)						刀片 Insert	刀垫 Pad	销钉 Pin	压板 Pressing plate	固定螺钉 Screw	弹簧 Screw	扳手 Wrench	
	R	L	h	b	L	L1	h1	f								
DDQNR/L1616H11	●	●	16	16	100	32	16	20								L4.0 L2.5
DDQNR/L2020K11	●	●	20	20	125	32	20	25	DN**1104	DN-1103	DXD0512	DYB2413B	ZZM0616	TH0810		
DDQNR/L2525M11	●	●	25	25	150	32	25	32								
DDQNR/L2020K1504	●	●	20	20	125	38	20	25								
DDQNR/L2525M1504	●	●	25	25	150	38	25	32	DN**1504	DN-1506	DXD0614	DYB3113	ZZM0616	TH0810	L4.0 L3.0	
DDQNR/L3232P1504	●	●	32	32	170	38	32	40								
DDQNR/L2020K1506	●	●	20	20	125	38	20	25								
DDQNR/L2525M1506	●	●	25	25	150	38	25	32	DN**1506	DN-1504	DXD0614	DYB3113	ZZM0616	TH0810	L4.0 L3.0	
DDQNR/L3232P1506	●	●	32	32	170	38	32	40								

DDPNN

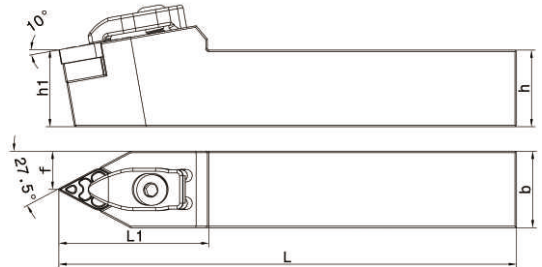

Ordering Code (规格型号)	Stock (库存)		Dimensions/mm (尺寸/mm)						刀片 Insert	刀垫 Pad	销钉 Pin	压板 Pressing plate	固定螺钉 Screw	弹簧 Screw	扳手 Wrench	
	R	L	h	b	L	L1	h1	f								
DDPNN1616H11	●	●	16	16	100	32	16	8								
DDPNN2020K11	●	●	20	20	125	32	20	10	DN**1104	DN-1103	DXD0512	DYB2413B	ZZM0616	TH0810	L4.0 L2.5	
DDPNN2525M11	●	●	25	25	150	32	25	12.5								
DDPNN2020K1504	●	●	20	20	125	46	20	10								
DDPNN2525M1504	●	●	25	25	150	46	25	12.5	DN**1504	DN-1506	DXD0614	DYB3113	ZZM0616	TH0810	L4.0 L3.0	
DDPNN3232P1504	●	●	32	32	170	46	32	16								
DDPNN2020K1506	●	●	20	20	125	46	20	10								
DDPNN2525M1506	●	●	25	25	150	46	25	12.5	DN**1506	DN-1504	DXD0614	DYB3113	ZZM0616	TH0810	L4.0 L3.0	
DDPNN3232P1506	●	●	32	32	170	46	32	16								

PSBNR/L

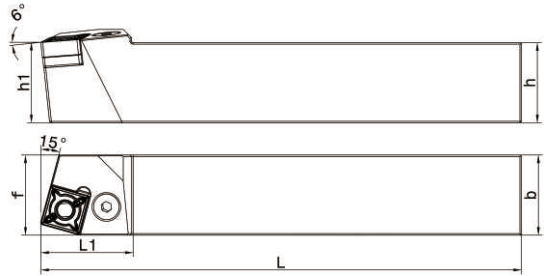

Ordering Code (规格型号)	Stock (库存)		Dimensions/mm (尺寸/mm)						刀片 Insert	刀垫 Pad	杠杆 Level	垫销 Shim	螺钉 Screw	扳手 Wrench	
	R	L	h	b	L	L1	h1	f							
PSBNR/L2020K12	●	●	20	20	125	28	20	20							L3.0
PSBNR/L2525M12	●	●	25	25	150	28	25	25	SN**1204	SN-P1203	GGX0514	DX0606	NLJ0820-P		
PSBNR/L3232P12	●	●	32	32	170	30	32	32							
PSBNR/L2525M15	●	●	25	25	150	35	25	25	SN**1506	SN-P1504	GGX0617	DX0808	NLJ0821-P		
PSBNR/L3232P15	●	●	32	32	170	35	32	32							
PSBNR/L3232P19	●	●	32	32	170	40	32	32	SN**1906	SN-P1904	GGX0820	DX0909	NLJ1027-P	L5.0	
PSBNR/L4040S19	●	●	40	40	250	42	40	40							
PSBNR/L4040S25	●	●	40	40	250	50	40	40	SN**2509	SN-P2506	GGX0925	DX1312	NLJ1237-P	L5.0	
PSBNR/L5050T25	●	●	50	50	300	50	50	50							

PSKNR/L

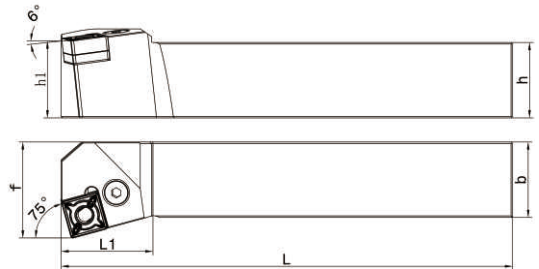
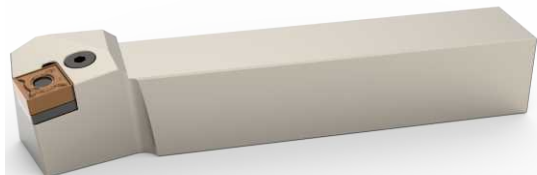

Ordering Code (规格型号)	Stock (库存)		Dimensions/mm (尺寸/mm)						刀片 Insert	刀垫 Pad	杠杆 Level	垫销 Shim	螺钉 Screw	扳手 Wrench	
	R	L	h	b	L	L1	h1	f							
PSKNR/L2020K12	●	●	20	20	125	28	20	25							L3.0
PSKNR/L2525M12	●	●	25	25	150	30	25	32	SN**1204	SN-P1203	GGX0514	DX0606	NLJ0820-P		
PSKNR/L3232P12	●	●	32	32	170	30	32	40							
PSKNR/L2525M15	●	●	25	25	150	32	25	32	SN**1506	SN-P1504	GGX0617	DX0808	NLJ0821-P		
PSKNR/L3232P15	●	●	32	32	170	32	32	40							
PSKNR/L3232P19	●	●	32	32	170	38	32	40	SN**1906	SN-P1904	GGX0820	DX0909	NLJ1027-P	L5.0	
PSKNR/L4040S19	●	●	40	40	250	38	40	50							
PSKNR/L4040S25	●	●	40	40	250	46	40	60	SN**2509	SN-P2506	GGX0925	DX1312	NLJ1237-P	L5.0	
PSKNR/L5050T25	●	●	50	50	300	46	50	60							

● Item in stock 标准库存 ○ Order on demand 无库存

DSDNN

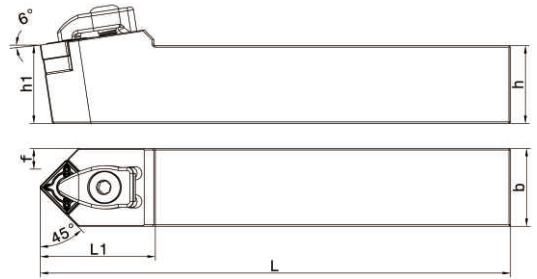

Ordering Code (规格型号)	Stock (库存)		Dimensions/mm (尺寸/mm)						刀片 Insert	刀垫 Pad	销钉 Pin	压板 Pressing plate	固定螺钉 Screw	弹簧 Screw	扳手 Wrench
	R	L	h	b	L	L1	h1	f							
DSDNN1616H12	●	●	16	16	100	36	16	8	SN**1204	SN-1204	DXD0614	DYB2413A	ZZM0616	TH0810	L3.0 L4.0
DSDNN2020K12	●	●	20	20	125	36	20	10							
DSDNN2525M12	●	●	25	25	150	36	25	12.5							
DSDNN3232P12	●	●	32	32	170	36	32	16							

DSSNR

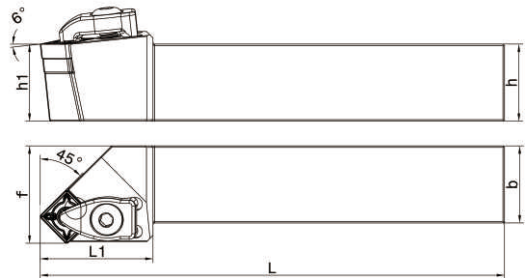

Ordering Code (规格型号)	Stock (库存)		Dimensions/mm (尺寸/mm)						刀片 Insert	刀垫 Pad	销钉 Pin	压板 Pressing plate	固定螺钉 Screw	弹簧 Screw	扳手 Wrench
	R	L	h	b	L	L1	h1	f							
DSSNR/L1616H12	●	●	16	16	100	34	16	20	SN**1204	SN-1204	DXD0614	DYB2413A	ZZM0616	TH0810	L3.0 L4.0
DSSNR/L2020K12	●	●	20	20	125	38	20	25							
DSSNR/L2525M12	●	●	25	25	150	38	25	32							
DSSNR/L3232P12	●	●	32	32	170	40	32	40							

PSSNR/L

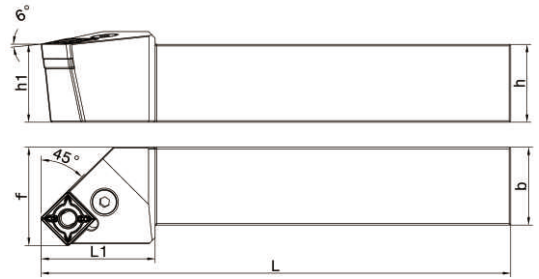

Ordering Code (规格型号)	Stock (库存)		Dimensions/mm (尺寸/mm)						刀片 Insert	刀垫 Pad	杠杆 Level	垫销 Shim	螺钉 Screw	扳手 Wrench	
	R	L	h	b	L	L1	h1	f							
PSSNR/L2020K12	●	●	20	20	125	30	20	25							L3.0
PSSNR/L2525M12	●	●	25	25	150	30	25	32	SN**1204	SN-P1203	GGX0514	DX0606	NLJ0820-P		
PSSNR/L3232P12	●	●	32	32	170	32	32	40							
PSSNR/L2525M15	●	●	25	25	150	36	25	32	SN**1506	SN-P1504	GGX0617	DX0808	NLJ0821-P		
PSSNR/L3232P15	●	●	32	32	170	36	32	40							
PSSNR/L3232P19	●	●	32	32	170	42	32	40	SN**1906	SN-P1904	GGX0820	DX0909	NLJ1027-P	L5.0	
PSSNR/L4040S19	●	●	40	40	250	42	40	50							
PSSNR/L4040S25	●	●	40	40	250	52	40	50	SN**2509	SN-P2506	GGX0925	DX1312	NLJ1237-P	L5.0	
PSSNR/L5050T25	●	●	50	50	300	52	50	60							

MTJNR/L

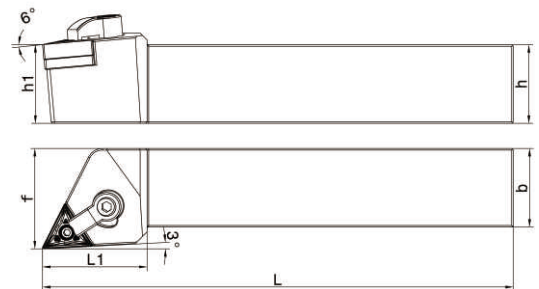

Ordering Code (规格型号)	Stock (库存)		Dimensions/mm (尺寸/mm)						刀片 Insert	刀垫 Pad	销钉 Pin	压板 Pressing plate	双头螺钉 Screw	扳手 Wrench	
	R	L	h	b	L	L1	h1	f							
MTJNR/L1616H16	●	●	16	16	100	33	16	20							L2.0 L3.0
MTJNR/L2020K16	●	●	20	20	125	33	20	25	TN**1604	TN-1603	MXD0514	MYB1814	ST0625		
MTJNR/L2525M16	●	●	25	25	150	33	25	32							

PTJNR/L

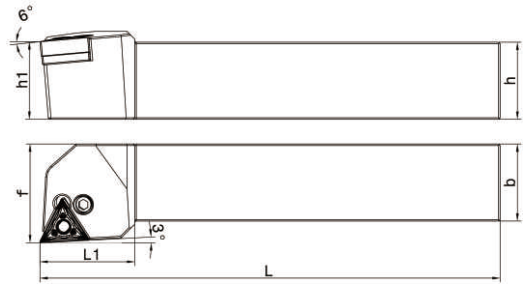

Ordering Code (规格型号)	Stock (库存)		Dimensions/mm (尺寸/mm)						刀片 Insert	刀垫 Pad	杠杆 Level	垫销 Shim	螺钉 Screw	扳手 Wrench	
	R	L	h	b	L	L1	h1	f							
PTJNR/L1616H16	●	●	16	16	100	26	16	20							
PTJNR/L2020K16	●	●	20	20	125	26	20	25	TN**1604	TN-P1602	GGX0310	DX0505	NLJ0618-P	L3.0	
PTJNR/L2525M16	●	●	25	25	150	26	25	32							

BTJNR/L

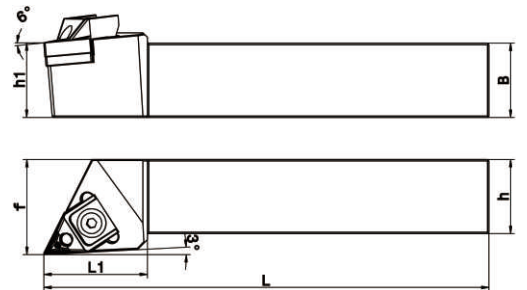

Ordering Code (规格型号)	Stock (库存)		Dimensions/mm (尺寸/mm)						刀片 Insert	刀垫 Pad	销钉 Pin	压板 Pressing plate	固定螺钉 Screw	弹簧 Screw	扳手 Wrench
	R	L	h	b	L	L1	h1	f							
BTJNR/L2020K16	●	●	20	20	125	33	20	25							
BTJNR/L2525M16	●	●	25	25	150	36	25	32	TN**1604	TN-1603	CTM5-S	BT16	BCS06	CR05	L2.5 L3.0

DTJNR/L

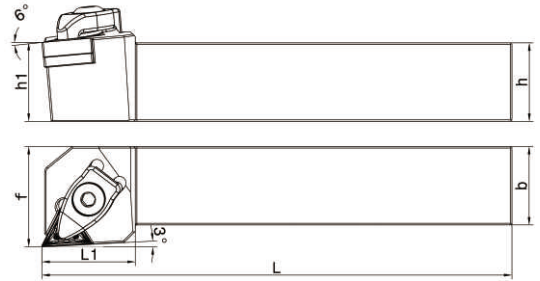

Ordering Code (规格型号)	Stock (库存)		Dimensions/mm (尺寸/mm)						刀片 Insert	刀垫 Pad	销钉 Pin	压板 Pressing plate	固定螺钉 Screw	弹簧 Screw	扳手 Wrench
	R	L	h	b	L	L1	h1	f							
DTJNR/L1616H16	●	●	16	16	100	32	16	20	TN**1604	TN-1603	DXD0512	DYB2413B	ZZM0616	TH0810	L2.5 L4.0
DTJNR/L2020K16	●	●	20	20	125	32	20	25							
DTJNR/L2525M16	●	●	25	25	150	32	25	32							
DTJNR/L3232P16	●	●	32	32	170	35	32	40							

WTJNR/L

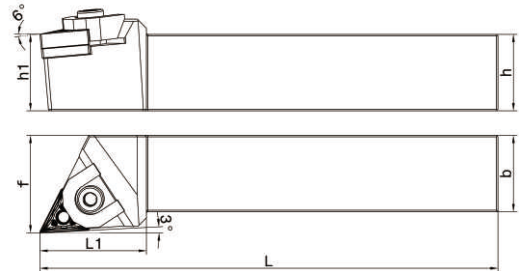
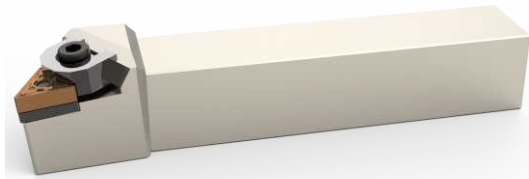

Ordering Code (规格型号)	Stock (库存)		Dimensions/mm (尺寸/mm)						刀片 Insert	刀垫 Pad	销钉 Pin	压板 Pressing plate	螺钉 Screw	弹簧 Screw	扳手 Wrench
	R	L	h	b	L	L1	h1	f							
WTJNR/L1616H16	●	●	16	16	100	35	16	20	TN**1604	TN-1603	WXD0513	WYB1816	NLJ0525	TH0810	L2.5 L4.0
WTJNR/L2020K16	●	●	20	20	125	35	20	25							
WTJNR/L2525M16	●	●	25	25	150	35	25	32							

DTQNR/L

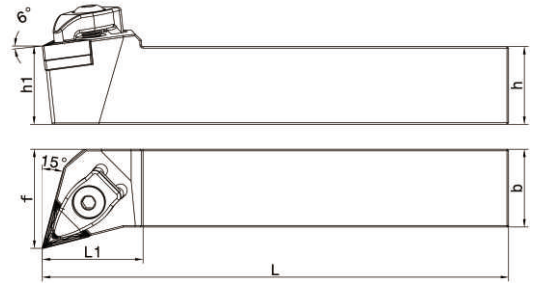

Ordering Code (规格型号)	Stock (库存)		Dimensions/mm (尺寸/mm)						刀片 Insert	刀垫 Pad	销钉 Pin	压板 Pressing plate	固定螺钉 Screw	弹簧 Screw	扳手 Wrench
	R	L	h	b	L	L1	h1	f							
DTQNR/L1616H16	●	●	16	16	100	32	16	20	TN**1604	TN-1603	DXD0512	DYB2413B	ZZM0616	TH0810	L2.5 L4.0
DTQNR/L2020K16	●	●	20	20	125	32	20	25							
DTQNR/L2525M16	●	●	25	25	150	32	25	32							
DTQNR/L3232P16	●	●	32	32	170	35	32	40							

DTFNR/L

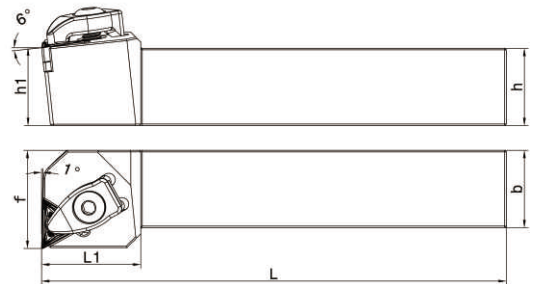

Ordering Code (规格型号)	Stock (库存)		Dimensions/mm (尺寸/mm)						刀片 Insert	刀垫 Pad	销钉 Pin	压板 Pressing plate	固定螺钉 Screw	弹簧 Screw	扳手 Wrench
	R	L	h	b	L	L1	h1	f							
DTFNR/L1616H16	●	●	16	16	100	32	16	20	TN**1604	TN-1603	DXD0512	DYB2413B	ZZM0616	TH0810	L2.5 L4.0
DTFNR/L2020K16	●	●	20	20	125	32	20	25							
DTFNR/L2525M16	●	●	25	25	150	32	25	32							
DTFNR/L3232P16	●	●	32	32	170	35	32	40							

DTGNR/L

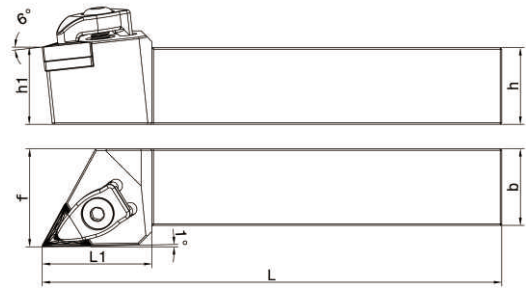

Ordering Code (规格型号)	Stock (库存)		Dimensions/mm (尺寸/mm)						刀片 Insert	刀垫 Pad	销钉 Pin	压板 Pressing plate	固定螺钉 Screw	弹簧 Screw	扳手 Wrench
	R	L	h	b	L	L1	h1	f							
DTGNR/L1616H16	●	●	16	16	100	32	16	20	TN**1604	TN-1603	DXD0512	DYB2413B	ZZM0616	TH0810	L2.5 L4.0
DTGNR/L2020K16	●	●	20	20	125	32	20	25							
DTGNR/L2525M16	●	●	25	25	150	32	25	32							
DTGNR/L3232P16	●	●	32	32	170	35	32	40							

WTENN

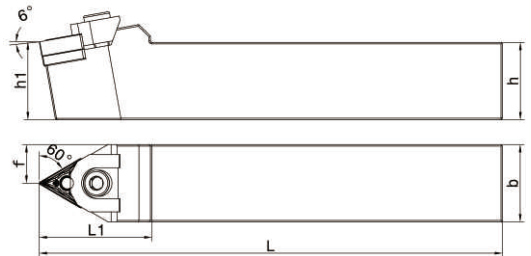

Ordering Code (规格型号)	Stock (库存)		Dimensions/mm (尺寸/mm)						刀片 Insert	刀垫 Pad	销钉 Pin	压板 Pressing plate	螺钉 Screw	弹簧 Screw	扳手 Wrench
	R	L	h	b	L	L1	h1	f							
WTENN1616H16	●	●	16	16	100	38	16	8	TN**1604	TN-1603	WXD0513	WYB1816	NLJ0525	TH0810	L2.5 L4.0
WTENN2020K16	●	●	20	20	125	38	20	10							
WTENN2525M16	●	●	25	25	150	38	25	12.5							

DVJNR/L

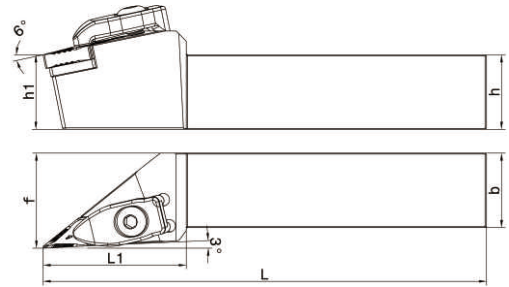

Ordering Code (规格型号)	Stock (库存)		Dimensions/mm (尺寸/mm)						刀片 Insert	刀垫 Pad	销钉 Pin	压板 Pressing plate	固定螺钉 Screw	扳手 Wrench
	R	L	h	b	L	L1	h1	f						
DVJNR/L1616H16	●	●	16	16	100	45	16	20	VN**1604	VN-1603	DXD0512	DYB3113	ZZM0616	L2.5 L4.0
DVJNR/L2020K16	●	●	20	20	125	45	20	25						
DVJNR/L2525M16	●	●	25	25	150	45	25	32						
DVJNR/L3232P16	●	●	32	32	170	48	32	40						

MVJNR/L

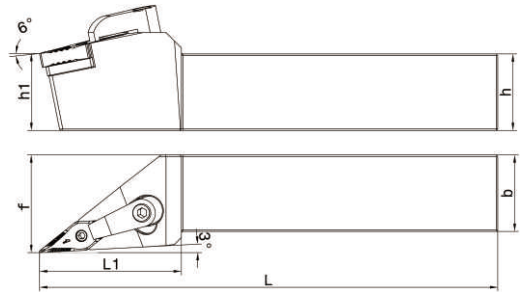
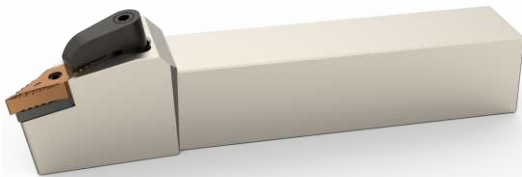

Ordering Code (规格型号)	Stock (库存)		Dimensions/mm (尺寸/mm)						刀片 Insert	刀垫 Pad	销钉 Pin	压板 Pressing plate	双头螺钉 Screw	扳手 Wrench
	R	L	h	b	L	L1	h1	f						
MVJNR/L1616H16	●	●	16	16	100	36	16	20	VN**1604	VN-1603	MXD0514	MYB2614	ST0625	L2.5 L3.0
MVJNR/L2020K16	●	●	20	20	125	36	20	25						
MVJNR/L2525M16	●	●	25	25	150	42	25	32						

BVJNR/L

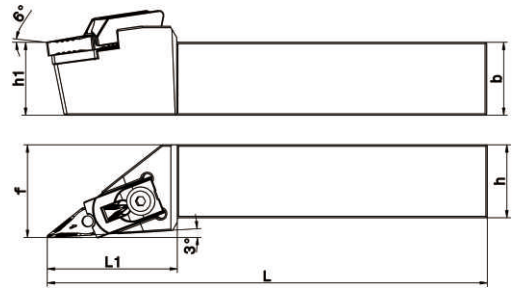

Ordering Code (规格型号)	Stock (库存)		Dimensions/mm (尺寸/mm)						刀片 Insert	刀垫 Pad	销钉 Pin	压板 Pressing plate	固定螺钉 Screw	弹簧 Screw	扳手 Wrench
	R	L	h	b	L	L1	h1	f							
BVJNR/L2020K16	●	●	20	20	125	33	20	25	VN**1604	VN-1603	CTM5-S	BV16	BCS06	CR05	L2.5 L3.0
BVJNR/L2525M16	●	●	25	25	150	36	25	32							

DVQNR/L

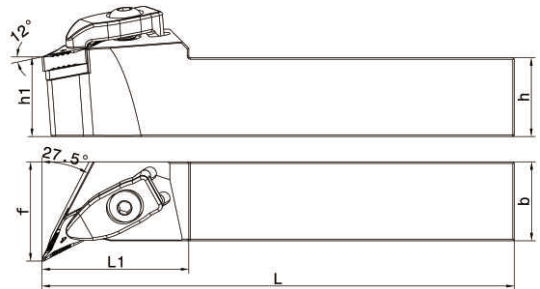

Ordering Code (规格型号)	Stock (库存)		Dimensions/mm (尺寸/mm)						刀片 Insert	刀垫 Pad	销钉 Pin	压板 Pressing plate	固定螺钉 Screw	弹簧 Screw	扳手 Wrench
	R	L	h	b	L	L1	h1	f							
DVQNR/L1616H16	●	●	16	16	100	44	16	20	VN**1604	VN-1603	DXD0512	DYB3113	ZZM0616	TH0810	L2.5 L4.0
DVQNR/L2020K16	●	●	20	20	125	44	20	25							
DVQNR/L2525M16	●	●	25	25	150	44	25	32							
DVQNR/L3232P16	●	●	32	32	170	46	32	40							

DVVNN

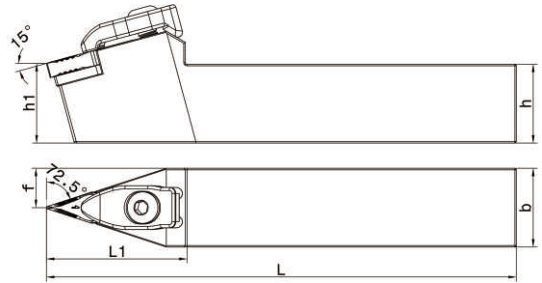

Ordering Code (规格型号)	Stock (库存)		Dimensions/mm (尺寸/mm)						刀片 Insert	刀垫 Pad	销钉 Pin	压板 Pressing plate	固定螺钉 Screw	扳手 Wrench
	R	L	h	b	L	L1	h1	f						
DVVNN1616H16	●	●	16	16	100	45	16	8	VN**1604	VN-1603	DXD0512	DYB3113	ZZM0616	L2.5 L4.0
DVVNN2020K16	●	●	20	20	125	48	20	10						
DVVNN2525M16	●	●	25	25	150	48	25	12.5						
DVVNN3232P16	●	●	32	32	170	48	32	16						

MWLNR/L

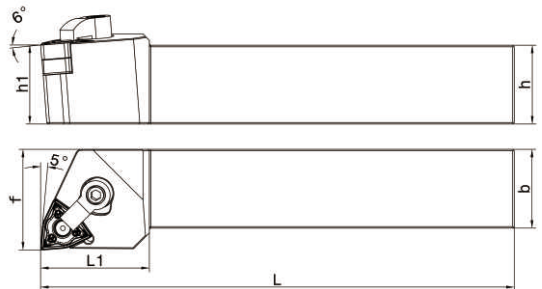
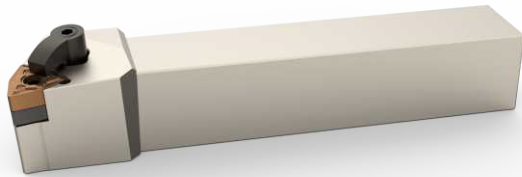

Ordering Code (规格型号)	Stock (库存)		Dimensions/mm (尺寸/mm)						刀片 Insert	刀垫 Pad	销钉 Pin	压板 Pressing plate	双头螺钉 Screw	扳手 Wrench
	R	L	h	b	L	L1	h1	f						
MWLNR/L1616H08	●	●	16	16	100	30	16	20	WN**0804	WN-0803	MXD0617	MYB1814	ST0625	L3.0
MWLNR/L2020K08	●	●	20	20	125	28	20	25						
MWLNR/L2525M08	●	●	25	25	150	28	25	32						

DWLNR/L

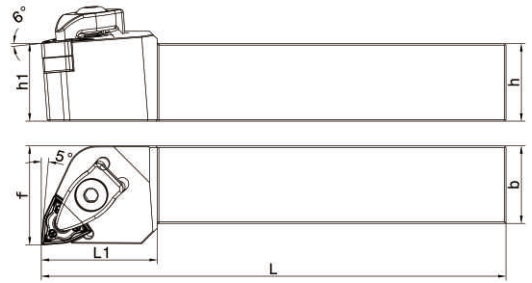

Ordering Code (规格型号)	Stock (库存)		Dimensions/mm (尺寸/mm)						刀片 Insert	刀垫 Pad	销钉 Pin	压板 Pressing plate	固定螺钉 Screw	弹簧 Screw	扳手 Wrench
	R	L	h	b	L	L1	h1	f							
DWLNR/L1616H06	●	●	16	16	100	28	16	20	WN**0604	WN-0603	DXD0512	DYB2413B	ZZM0616	TH0810	L2.5 L4.0
DWLNR/L2020K06	●	●	20	20	125	28	20	25							
DWLNR/L2525M06	●	●	25	25	150	30	25	32							
DWLNR/L1616H08	●	●	16	16	100	30	16	20	WN**0804	WN-0804	DXD0614	DYB2413A	ZZM0616	TH0810	L3.0 L4.0
DWLNR/L2020K08	●	●	20	20	125	36	20	25							
DWLNR/L2525M08	●	●	25	25	150	36	25	32							
DWLNR/L3232P08	●	●	32	32	170	36	32	40							

BWLNR/L

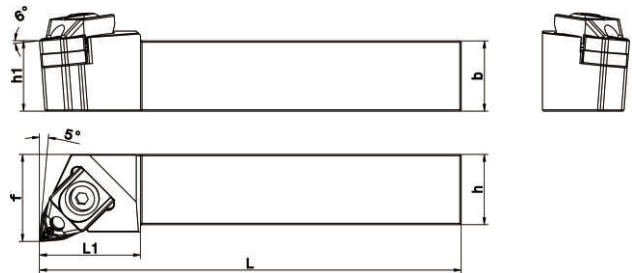
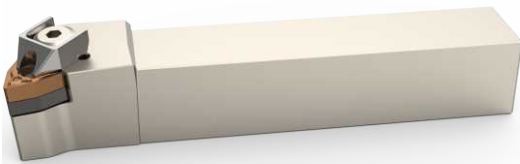

Ordering Code (规格型号)	Stock (库存)		Dimensions/mm (尺寸/mm)						刀片 Insert	刀垫 Pad	销钉 Pin	压板 Pressing plate	固定螺钉 Screw	弹簧 Screw	扳手 Wrench
	R	L	h	b	L	L1	h1	f							
BWLNR/L2020K06	●	●	20	20	125	25	20	25	WN**0604	WN-0604	CTM5-S	BW06	BCS06	CR05	L2.5 L3.0
BWLNR/L2525M06	●	●	25	25	150	31	25	32							
BWLNR/L2020K08	●	●	20	20	125	31	20	25	WN**0804	WN-0804	CTM6-S	BW08	BSC08	CR07	L3.0 L4.0
BWLNR/L2525M08	●	●	25	25	150	36	25	32							

PWLNR/L

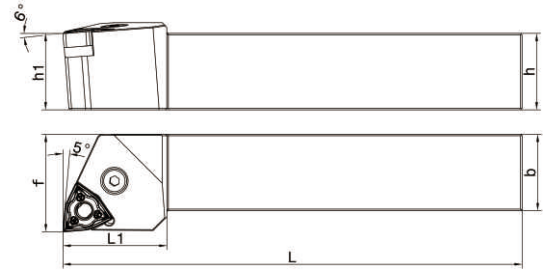

Ordering Code (规格型号)	Stock (库存)		Dimensions/mm (尺寸/mm)						刀片 Insert	刀垫 Pad	杠杆 Level	垫销 Shim	螺钉 Screw	扳手 Wrench
	R	L	h	b	L	L1	h1	f						
PWLNR/L1616H08	●	●	16	16	100	26	16	20						
PWLNR/L2020K08	●	●	20	20	125	26	20	25	WN**0804	WN-P0803	GGX0514	DX0606	NLJ0820-P	L3.0
PWLNR/L2525M08	●	●	25	25	150	26	25	32						

SCLCR/L

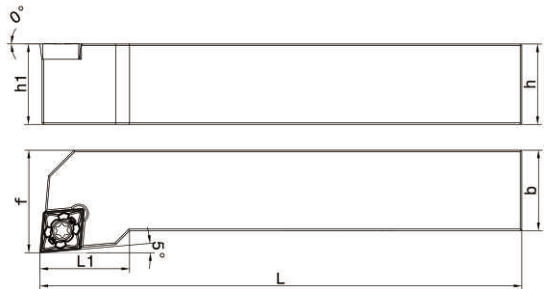
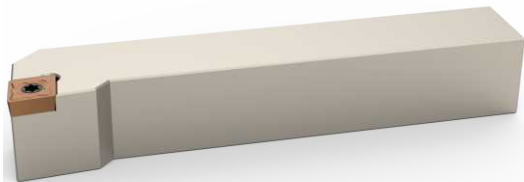

Ordering Code (规格型号)	Stock (库存)		Dimensions/mm (尺寸/mm)						刀片 Insert	螺钉 Screw	扳手 Wrench
	R	L	h	b	L	L1	h1	f			
SCLCR/L1010H06	●	●	10	10	100	15	10	12	CC**0602	MT2.5*6	FT-8
SCLCR/L1212H06	●	●	12	12	100	15	12	16			
SCLCR/L1212H09	●	●	12	12	100	20	12	16			
SCLCR/L1616H09	●	●	16	16	100	20	16	20	CC**09T3	MT3.5*8	FT-15
SCLCR/L2020K09	●	●	20	20	125	22	20	25			
SCLCR/L2525M09	●	●	25	25	150	22	25	32			
SCLCR/L2020K12	●	●	20	20	125	22	20	25	CC**1204	MS5*11	FT-20
SCLCR/L2525M12	●	●	25	25	150	28	25	32			

SCKCR/L

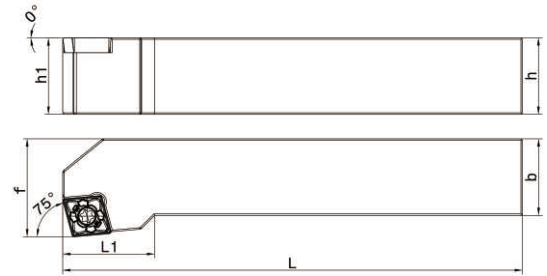

Ordering Code (规格型号)	Stock (库存)		Dimensions/mm (尺寸/mm)						刀片 Insert	螺钉 Screw	扳手 Wrench
	R	L	h	b	L	L1	h1	f			
SCKCR/L1616H09	●	●	16	16	100	22	16	20	CC**09T3	MT3.5*8	FT-15
SCKCR/L2020K09	●	●	20	20	125	22	20	25			
SCKCR/L2525M09	●	●	25	25	150	22	25	32			

SCBCR/L

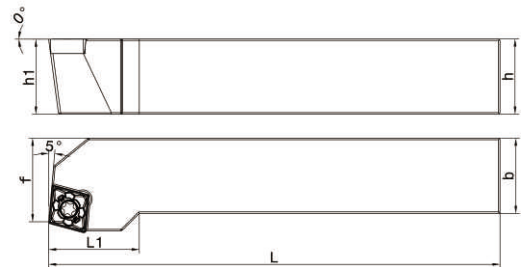

Ordering Code (规格型号)	Stock (库存)		Dimensions/mm (尺寸/mm)						刀片 Insert	螺钉 Screw	扳手 Wrench
	R	L	h	b	L	L1	h1	f			
SCBCR/L1616H09	●	●	16	16	100	22	16	20	CC**09T3	MT3.5*8	FT-15
SCBCR/L2020K09	●	●	20	20	125	22	20	25			
SCBCR/L2525M09	●	●	25	25	150	22	25	32			

SDJCR/L

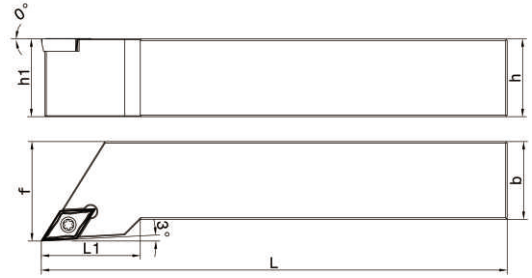
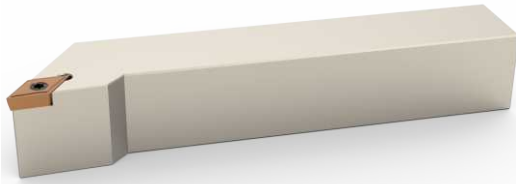

Ordering Code (规格型号)	Stock (库存)		Dimensions/mm (尺寸/mm)						刀片 Insert	螺钉 Screw	扳手 Wrench
	R	L	h	b	L	L1	h1	f			
SDJCR/L1010H07	●	●	10	10	100	16	10	12	DC**0702	MT2.5*6	FT-8
SDJCR/L1212H07	●	●	12	12	100	16	12	16			
SDJCR/L1616H07	●	●	16	16	100	20	16	20			
SDJCR/L1212H11	●	●	12	12	100	22	12	16	DC**11T3	MT3.5*8	FT-15
SDJCR/L1616H11	●	●	16	16	100	22	16	20			
SDJCR/L2020K11	●	●	20	20	125	25	20	25			
SDJCR/L2525M11	●	●	25	25	150	32	25	32			

SDQCR/L

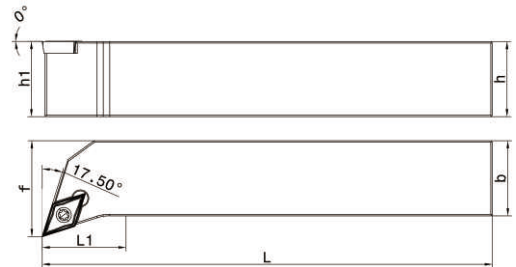

Ordering Code (规格型号)	Stock (库存)		Dimensions/mm (尺寸/mm)						刀片 Insert	螺钉 Screw	扳手 Wrench
	R	L	h	b	L	L1	h1	f			
SDQCR/L1010H07	●	●	10	10	100	16	10	12	DC**0702	MT2.5*6	FT-8
SDQCR/L1212H07	●	●	12	12	100	16	12	16			
SDQCR/L1616H07	●	●	16	16	100	20	16	20			
SDQCR/L1212H11	●	●	12	12	100	18	12	16	DC**11T3	MT3.5*8	FT-15
SDQCR/L1616H11	●	●	16	16	100	22	16	20			
SDQCR/L2020K11	●	●	20	20	125	25	20	25			
SDQCR/L2525M11	●	●	25	25	150	32	25	32			

SDFCR/L

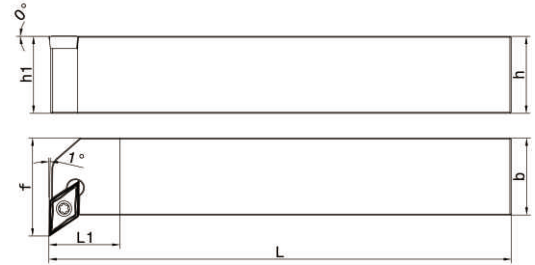
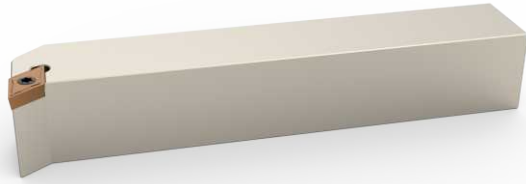

Ordering Code (规格型号)	Stock (库存)		Dimensions/mm (尺寸/mm)						刀片 Insert	螺钉 Screw	扳手 Wrench
	R	L	h	b	L	L1	h1	f			
SDFCR/L1212H07	●	●	12	12	100	16	12	16	DC**0702	MT2.5*6	FT-8
SDFCR/L1616H11	●	●	16	16	100	18	16	20	DC**11T3	MT3.5*8	FT-15
SDFCR/L2020K11	●	●	20	20	125	22	20	25			
SDFCR/L2525M11	●	●	25	25	150	22	25	32			

SDACR/L

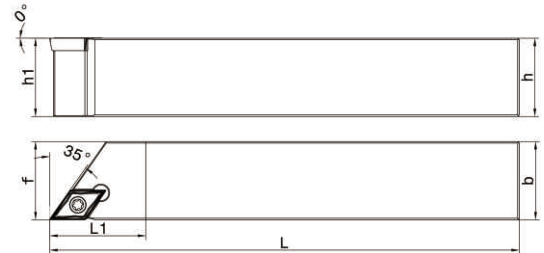

Ordering Code (规格型号)	Stock (库存)		Dimensions/mm (尺寸/mm)						刀片 Insert	螺钉 Screw	扳手 Wrench
	R	L	h	b	L	L1	h1	f			
SDACR/L1010H07	●	●	10	10	100	15	10	10	DC**0702	MT2.5*6	FT-8
SDACR/L1212H07	●	●	12	12	100	15	12	12			
SDACR/L1616H07	●	●	16	16	100	15	16	16			
SDACR/L1212H11	●	●	12	12	100	22	12	12	DC**11T3	MT3.5*8	FT-15
SDACR/L1616H11	●	●	16	16	100	22	16	16			
SDACR/L2020K11	●	●	20	20	125	22	20	20			
SDACR/L2525M11	●	●	25	25	150	22	25	25			

SDNCN

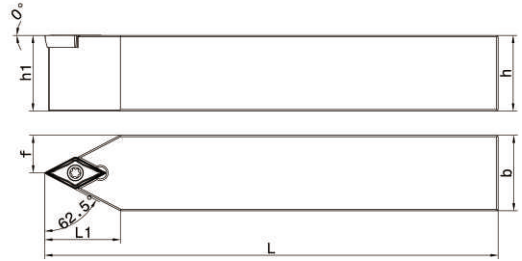

Ordering Code (规格型号)	Stock (库存)		Dimensions/mm (尺寸/mm)						刀片 Insert	螺钉 Screw	扳手 Wrench
	R	L	h	b	L	L1	h1	f			
SDNCN1010H07	●	●	10	10	100	16	10	5	DC**0702	MT2.5*6	FT-8
SDNCN1212H07	●	●	12	12	100	18	12	6			
SDNCN1616H07	●	●	16	16	100	20	16	8			
SDNCN1212H11	●	●	12	12	100	22	12	6	DC**11T3	MT3.5*8	FT-15
SDNCN1616H11	●	●	16	16	100	27	16	8			
SDNCN2020K11	●	●	20	20	125	27	20	10			

SSBCR/L

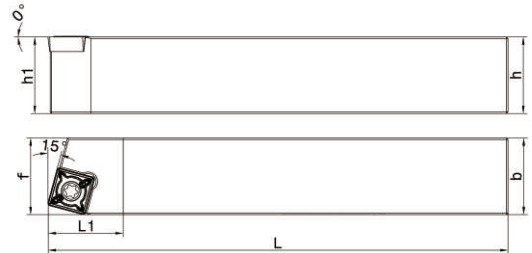

Ordering Code (规格型号)	Stock (库存)		Dimensions/mm (尺寸/mm)						刀片 Insert	螺钉 Screw	扳手 Wrench
	R	L	h	b	L	L1	h1	f			
SSBCR/L1212H09	●	●	12	12	100	16	12	12	SC**09T3	MT3.5*8	FT-15
SSBCR/L1616H09	●	●	16	16	100	20	16	16			
SSBCR/L2020K09	●	●	20	20	125	20	20	20			

SSKCR/L

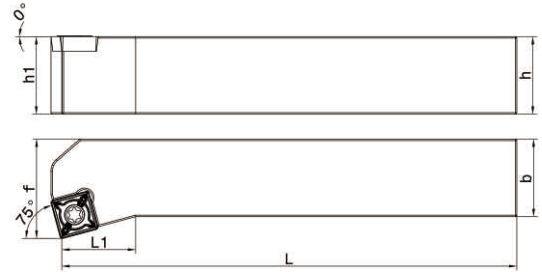

Ordering Code (规格型号)	Stock (库存)		Dimensions/mm (尺寸/mm)						刀片 Insert	螺钉 Screw	扳手 Wrench
	R	L	h	b	L	L1	h1	f			
SSKCR/L1212H09	●	●	12	12	100	16	12	12	SC**09T3	MT3.5*8	FT-15
SSKCR/L1616H09	●	●	16	16	100	18	16	16			
SSKCR/L2020K09	●	●	20	20	125	22	20	25			
SSKCR/L2020K12	●	●	20	20	125	22	20	25	SC**1204	MT5*11	FT-20
SSKCR/L2525M12	●	●	25	25	150	30	25	32			

SSSCR/L

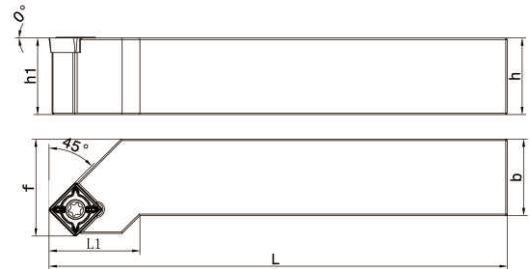

Ordering Code (规格型号)	Stock (库存)		Dimensions/mm (尺寸/mm)						刀片 Insert	螺钉 Screw	扳手 Wrench
	R	L	h	b	L	L1	h1	f			
SSSCR/L1212H09	●	●	12	12	100	20	12	16	SC**09T3	MT3.5*8	FT-15
SSSCR/L1616H09	●	●	16	16	100	22	16	20			
SSSCR/L2020K09	●	●	20	20	125	25	20	25			
SSSCR/L2020K12	●	●	20	20	125	25	20	25	SC**1204	MT5*11	FT-20
SSSCR/L2525M12	●	●	25	25	150	30	25	32			

STGCR/L

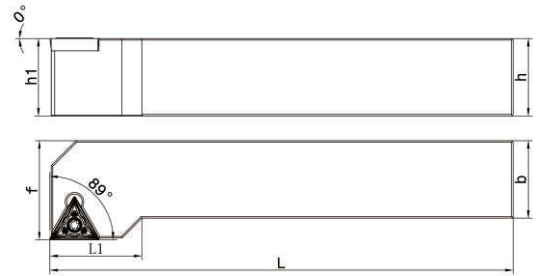

Ordering Code (规格型号)	Stock (库存)		Dimensions/mm (尺寸/mm)						刀片 Insert	螺钉 Screw	扳手 Wrench
	R	L	h	b	L	L1	h1	f			
STGCR/L1212H11	●	●	12	12	100	18	12	16	TC**1102	MT2.5*6	FT-8
STGCR/L1616H11	●	●	16	16	100	20	16	20			
STGCR/L2020K16	●	●	20	20	125	30	20	25	TC**16T3	MT3.5*8	FT-15
STGCR/L2525M16	●	●	25	25	150	30	25	32			

STFCR/L

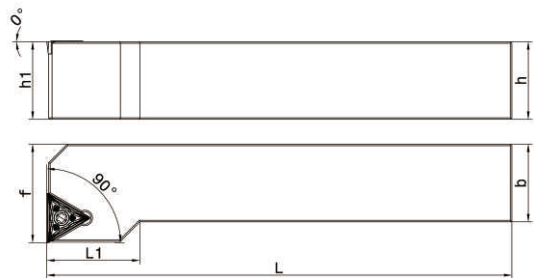
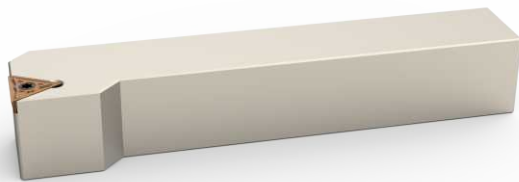

Ordering Code (规格型号)	Stock (库存)		Dimensions/mm (尺寸/mm)						刀片 Insert	螺钉 Screw	扳手 Wrench
	R	L	h	b	L	L1	h1	f			
STFCR/L1212H11	●	●	12	12	100	18	12	16	TC**1102	MT2.5*6	FT-8
STFCR/L1616H11	●	●	16	16	100	20	16	20			
STFCR/L2020K16	●	●	20	20	125	23	20	25	TC**16T3	MT3.5*8	FT-15
STFCR/L2525M16	●	●	25	25	150	30	25	32			

SVJCR/L

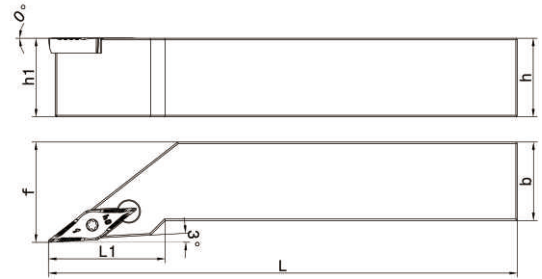

Ordering Code (规格型号)	Stock (库存)		Dimensions/mm (尺寸/mm)						刀片 Insert	螺钉 Screw	扳手 Wrench
	R	L	h	b	L	L1	h1	f			
SVJCR/L1010H11	●	●	10	10	100	25	12	16	VC**1103	MT2.5*6	FT-8
SVJCR/L1212H11	●	●	12	12	100	25	12	16			
SVJCR/L1616H11	●	●	16	16	100	28	16	20			
SVJCR/L2020K11	●	●	20	20	125	35	20	25			
SVJCR/L2525M11	●	●	25	25	150	35	25	32			
SVJCR/L1616H16	●	●	16	16	100	32	16	20	VC**1604	MT3.5*8	FT-15
SVJCR/L2020K16	●	●	20	20	125	38	20	25			
SVJCR/L2525M16	●	●	25	25	150	45	25	32			

SVQCR/L

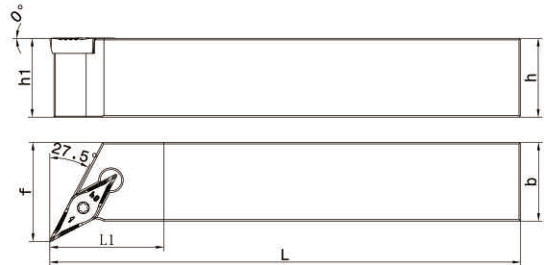
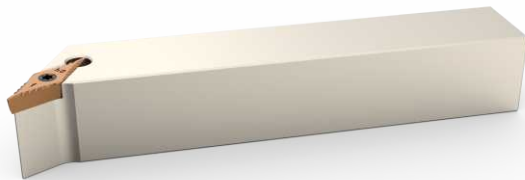

Ordering Code (规格型号)	Stock (库存)		Dimensions/mm (尺寸/mm)						刀片 Insert	螺钉 Screw	扳手 Wrench
	R	L	h	b	L	L1	h1	f			
SVQCR/L1616H11	●	●	16	16	100	35	16	20	VC**1103	MT2.5*6	FT-8
SVQCR/L2020K11	●	●	20	20	125	35	20	25			
SVQCR/L1616H16	●	●	16	16	100	35	16	20	VC**1604	MT3.5*8	FT-15
SVQCR/L2020K16	●	●	20	20	125	35	20	25			
SVQCR/L2525M16	●	●	25	25	150	35	25	32			

SVJBR/L

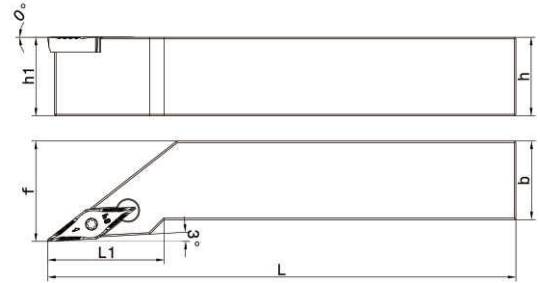

Ordering Code (规格型号)	Stock (库存)		Dimensions/mm (尺寸/mm)						刀片 Insert	螺钉 Screw	扳手 Wrench
	R	L	h	b	L	L1	h1	f			
SVJBR/L1010H11	●	●	10	10	100	25	12	16	VB**1103	MT2.5*6	FT-8
SVJBR/L1212H11	●	●	12	12	100	25	12	16			
SVJBR/L1616H11	●	●	16	16	100	28	16	20			
SVJBR/L2020K11	●	●	20	20	125	35	20	25			
SVJBR/L2525M11	●	●	25	25	150	35	25	32	VB**1604	MT3.5*8	FT-15
SVJBR/L1616H16	●	●	16	16	100	32	16	20			
SVJBR/L2020K16	●	●	20	20	125	38	20	25			
SVJBR/L2525M16	●	●	25	25	150	45	25	32			

SVQBR/L

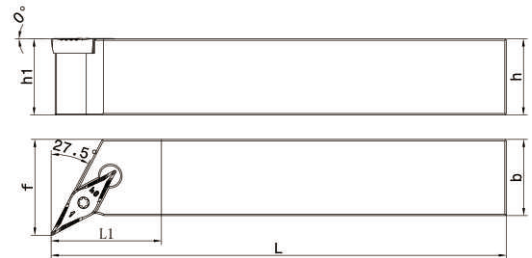
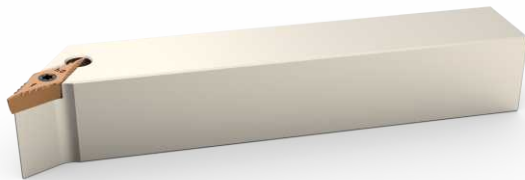

Ordering Code (规格型号)	Stock (库存)		Dimensions/mm (尺寸/mm)						刀片 Insert	螺钉 Screw	扳手 Wrench
	R	L	h	b	L	L1	h1	f			
SVQBR/L1616H11	●	●	16	16	100	35	16	20	VB**1103	MT2.5*6	FT-8
SVQBR/L2020K11	●	●	20	20	125	35	20	25			
SVQBR/L1616H16	●	●	16	16	100	35	16	20	VB**1604	MT3.5*8	FT-15
SVQBR/L2020K16	●	●	20	20	125	35	20	25			
SVQBR/L2525M16	●	●	25	25	150	35	25	32			

SVVCN

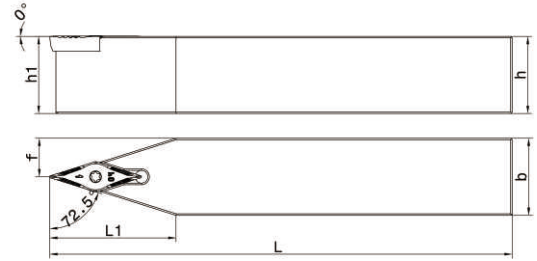
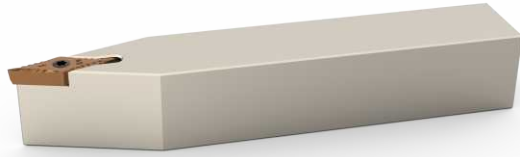

Ordering Code (规格型号)	Stock (库存)		Dimensions/mm (尺寸/mm)						刀片 Insert	螺钉 Screw	扳手 Wrench
	R	L	h	b	L	L1	h1	f			
SVVCN1010H11	●	●	10	10	100	25	10	5	VC**1103	MT2.5*6	FT-8
SVVCN1212H11	●	●	12	12	100	25	12	6			
SVVCN1616H11	●	●	16	16	100	28	16	8			
SVVCN2020K11	●	●	20	20	125	35	20	10	VC**1604	MT3.5*8	FT-15
SVVCN1616H16	●	●	16	16	100	32	16	8			
SVVCN2020K16	●	●	20	20	125	35	20	10			
SVVCN2525M16	●	●	25	25	150	38	25	12.5			

SVVBN

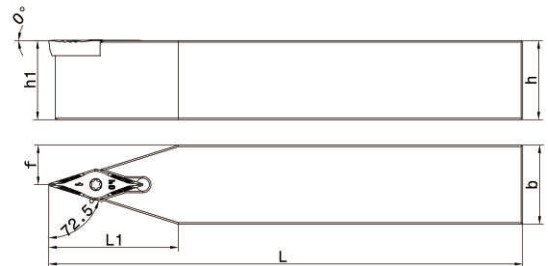

Ordering Code (规格型号)	Stock (库存)		Dimensions/mm (尺寸/mm)						刀片 Insert	螺钉 Screw	扳手 Wrench
	R	L	h	b	L	L1	h1	f			
SVVBN1010H11	●	●	10	10	100	25	10	5	VB**1103	MT2.5*6	FT-8
SVVBN1212H11	●	●	12	12	100	25	12	6			
SVVBN1616H11	●	●	16	16	100	28	16	8			
SVVBN2020K11	●	●	20	20	125	35	20	10	VB**1604	MT3.5*8	FT-15
SVVBN1616H16	●	●	16	16	100	32	16	8			
SVVBN2020K16	●	●	20	20	125	35	20	10			
SVVBN2525M16	●	●	25	25	150	38	25	12.5			

SRACR/L

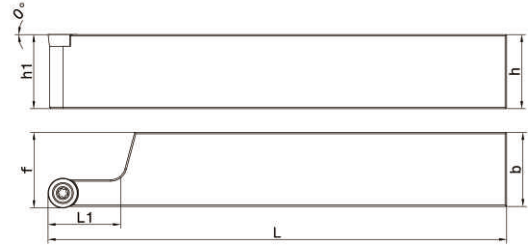

Ordering Code (规格型号)	Stock (库存)		Dimensions/mm (尺寸/mm)						刀片 Insert	螺钉 Screw	扳手 Wrench
	R	L	h	b	L	L1	h1	f			
SRACR/L1616H08	●	●	16	16	100	15	16	16	RC**0803	MT3*8	FT-8
SRACR/L2020K08	●	●	20	20	125	20	20	20			
SRACR/L2525M08	●	●	25	25	150	20	25	25			
SRACR/L1616H10	●	●	16	16	100	15	16	16	RC**10T3	MT3.5*10	FT-15
SRACR/L2020K10	●	●	20	20	125	20	20	20			
SRACR/L2525M10	●	●	25	25	150	20	25	25			
SRACR/L2020K12	●	●	20	20	100	20	20	20	RC**1204	MT3.5*10	FT-15
SRACR/L2525M12	●	●	25	25	125	20	25	25			

SRDCN

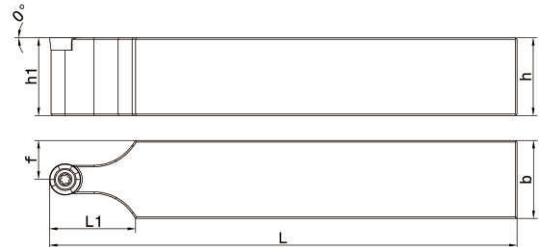

Ordering Code (规格型号)	Stock (库存)		Dimensions/mm (尺寸/mm)						刀片 Insert	螺钉 Screw	扳手 Wrench
	R	L	h	b	L	L1	h1	f			
SRDCN1616H08	●	●	16	16	100	15	16	16	RC**0803	MT3*8	FT-8
SRDCN2020K08	●	●	20	20	125	20	20	20			
SRDCN2525M08	●	●	25	25	150	20	25	25			
SRDCN1616H10	●	●	16	16	100	15	16	16	RC**10T3	MT3.5*10	FT-15
SRDCN2020K10	●	●	20	20	125	20	20	20			
SRDCN2525M10	●	●	25	25	150	20	25	25			
SRDCN2020K12	●	●	20	20	100	20	20	20	RC**1204	MT3.5*10	FT-15
SRDCN2525M12	●	●	25	25	125	20	25	25			